

DCM 2,0/1,2/23

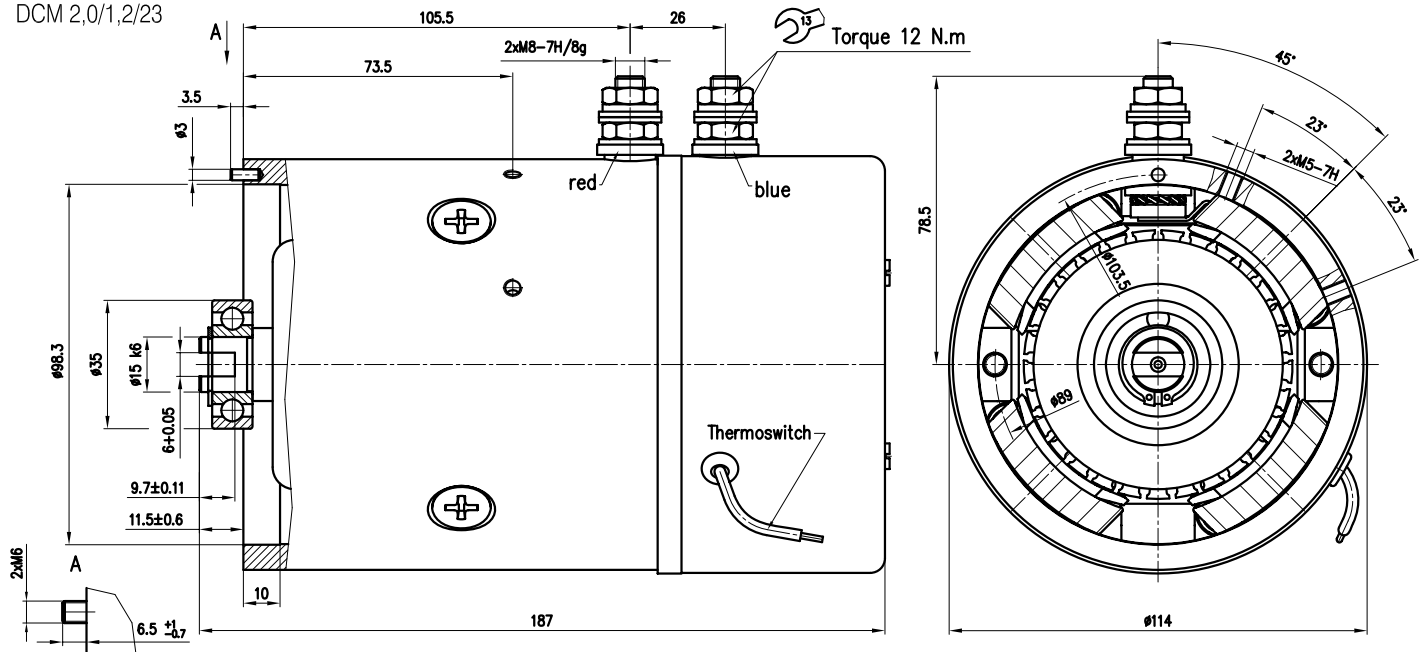

DCM 2,0/1,2/23-01

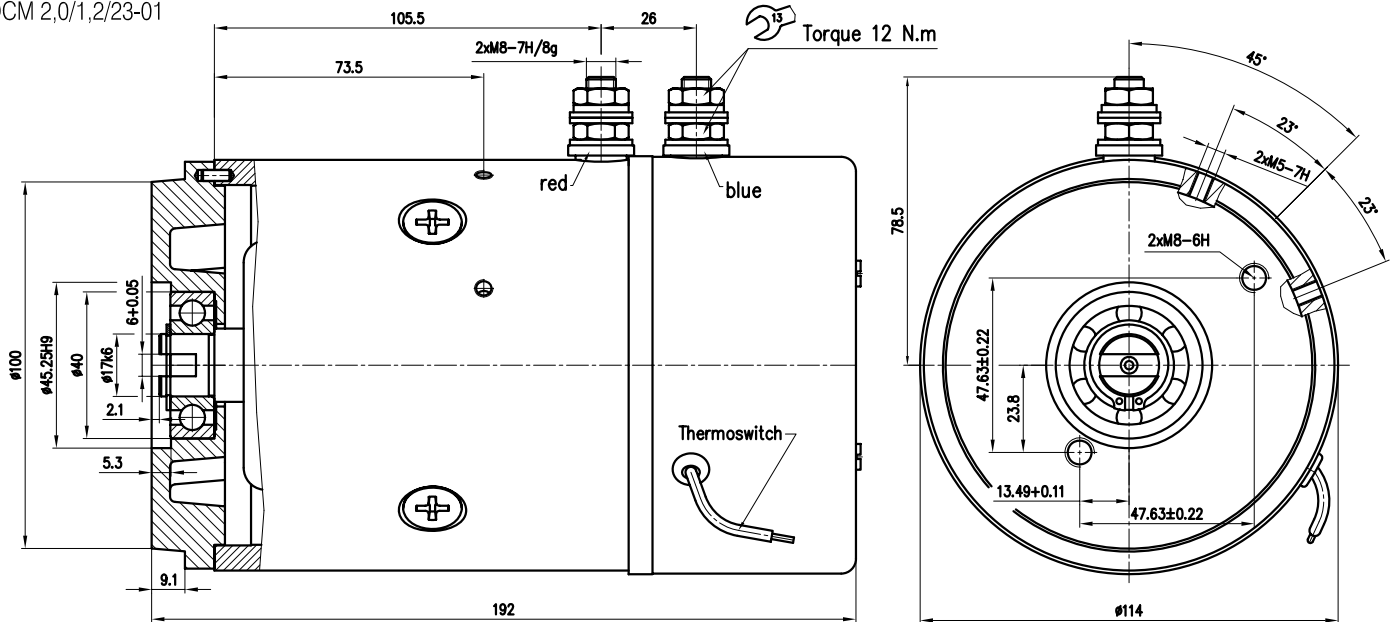

DCM 2,0/1,2/23

DCM 2,0/1,2/23-01

- Rated Power 2 kW
- Rated Voltage 12 V
- Rated Current 270 A
- Rated Speed 2300 min.⁻¹
- Operation Mode S2 - 1.5 min.
- Excitation Compound
- Protection IP 44
- Insulation F
- Weight 6.8 kg / 7.1 kg
- Char. Curve C12 B01
- Rotation C.W.D.E

Connection Diagram

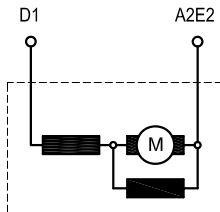

Design versions are adapted to standard assembly dimensions of hydraulic pumps and made according to special requirements of the customers

CAPRONI HOLDING JSC

6100 Kazanlak, BULGARIA
1, Vozheli Str.
Tel: +359 /431/62 229
Fax: +359 /431/ 62 230
E-mail: cip_ltd@mbox.digsys.bg
WEB: http://www.caproni.bg

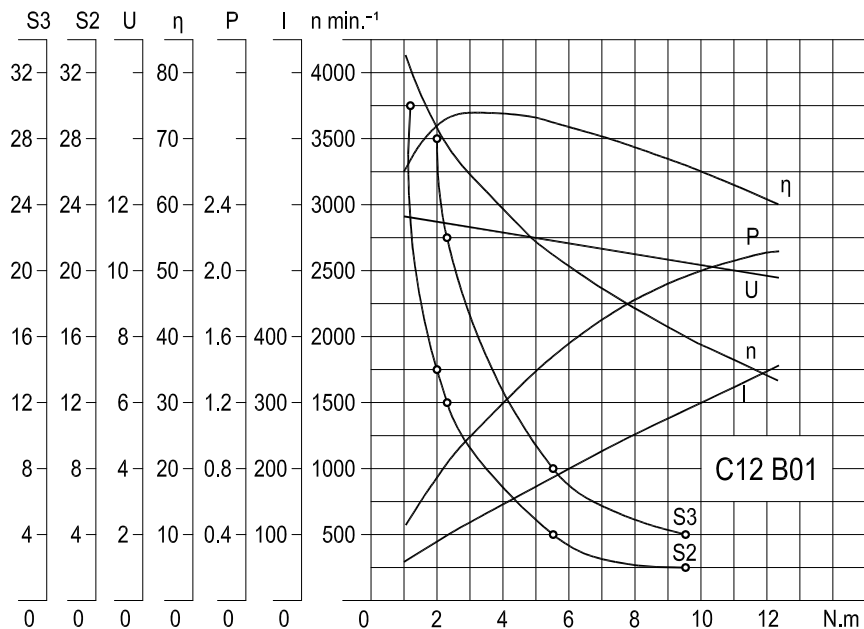

DCM 2,0/2,4/23

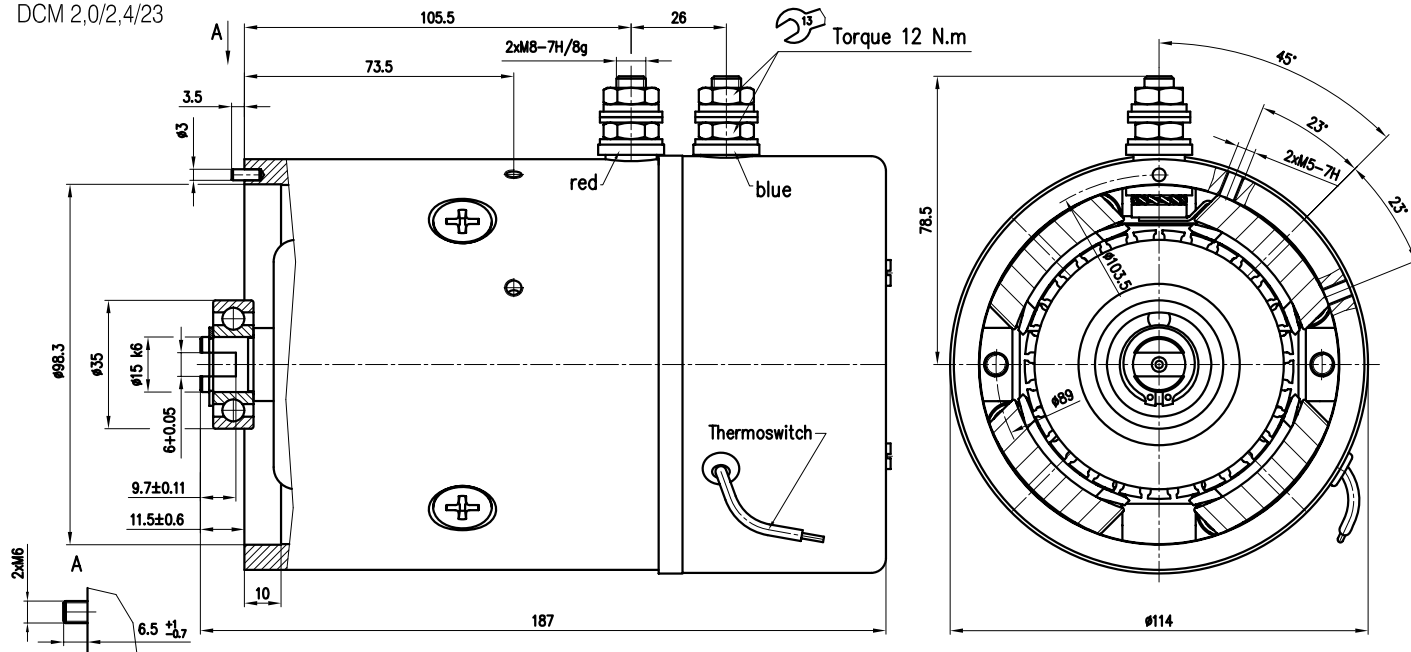

DCM 2,0/2,4/23-01

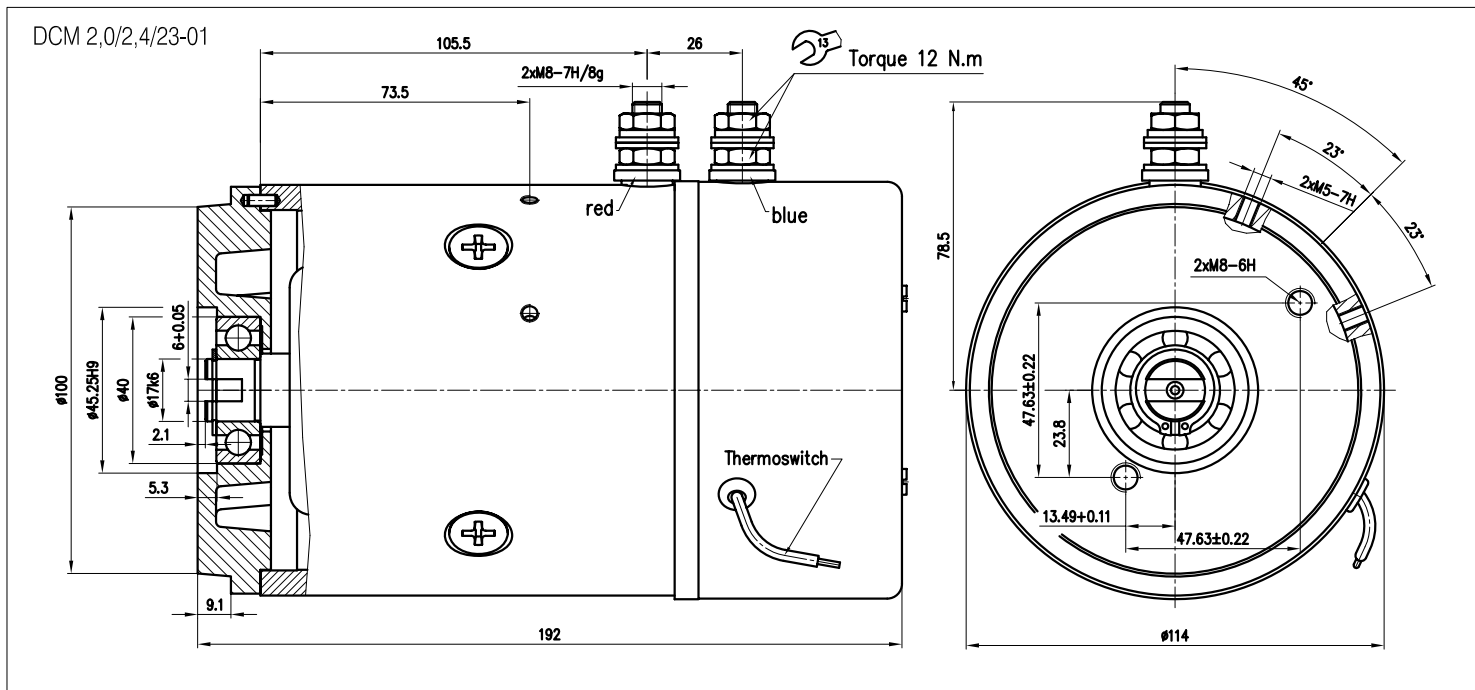

DCM 2,0/2,4/23

DCM 2,0/2,4/23-01

- Rated Power 2 kW
- Rated Voltage 24 V
- Rated Current 121 A
- Rated Speed 2300 min.⁻¹
- Operation Mode S2 - 2 min.
- Excitation Compound
- Protection IP 44
- Insulation F
- Weight 6.8 kg / 7.1 kg
- Char. Curve C24 B01
- Rotation C.W.D.E

Connection Diagram

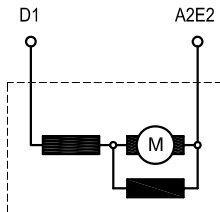

Design versions are adapted to standard assembly dimensions of hydraulic pumps and made according to special requirements of the customers

CAPRONI HOLDING JSC

6100 Kazanlak, BULGARIA
1, Vozheli Str.
Tel: +359 /431/62 229
Fax: +359 /431/ 62 230
E-mail: cip_ltd@mbox.digsys.bg
WEB: <http://www.caproni.bg>

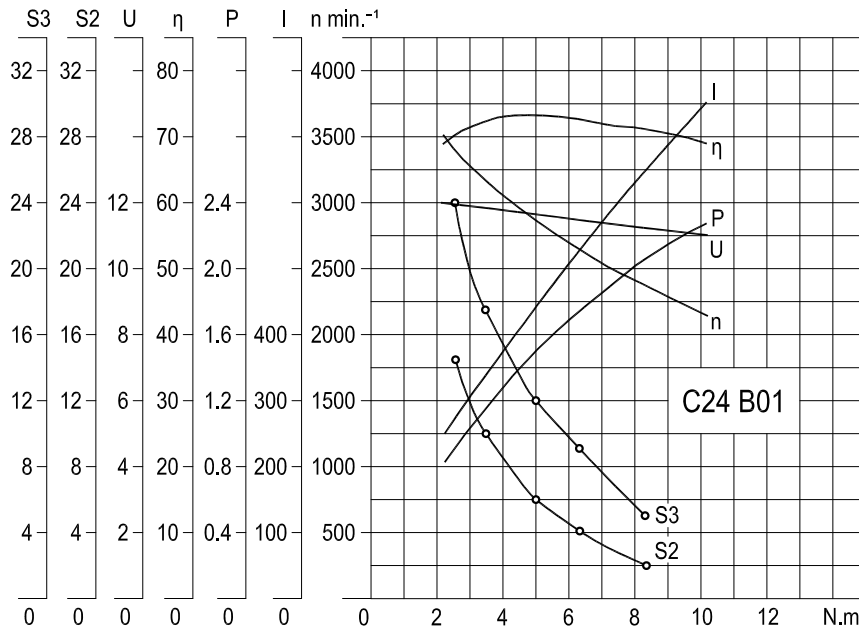

DCM 1,5/1,2/27

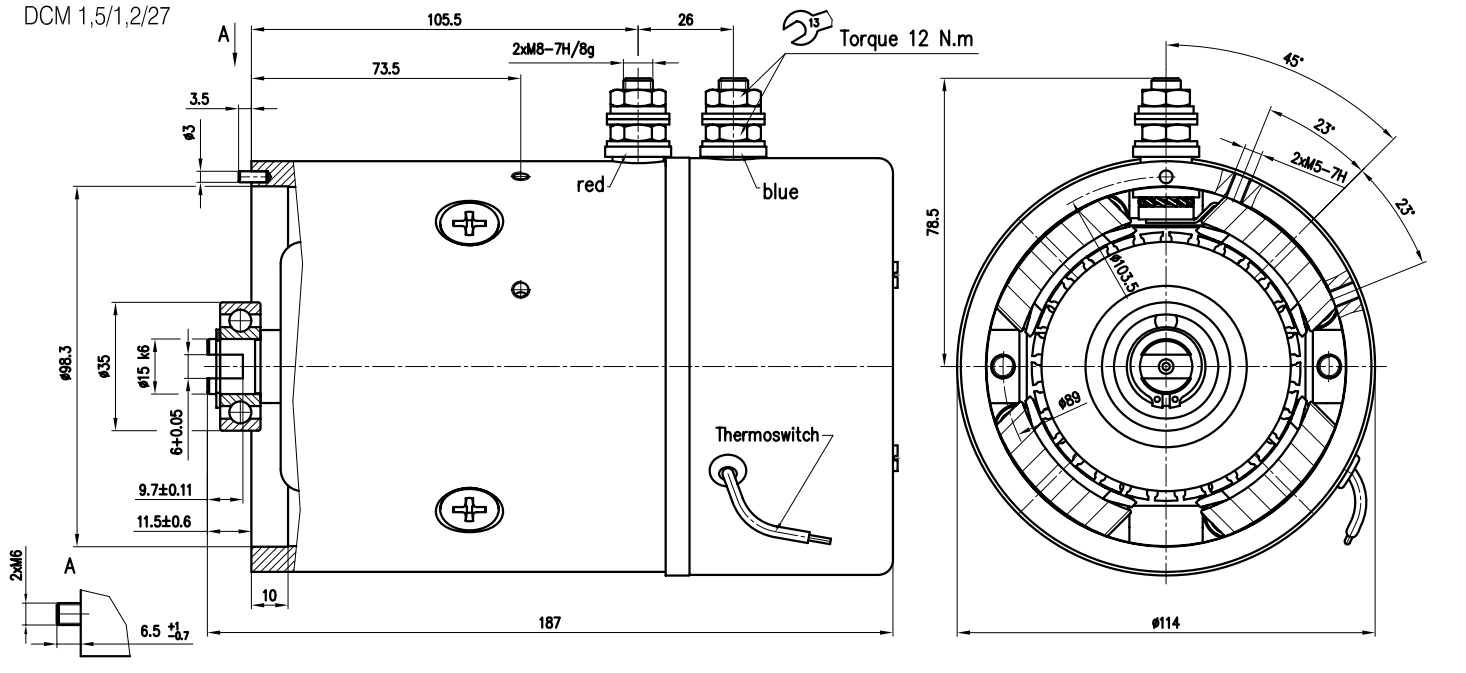

DCM 1,5/1,2/27-01

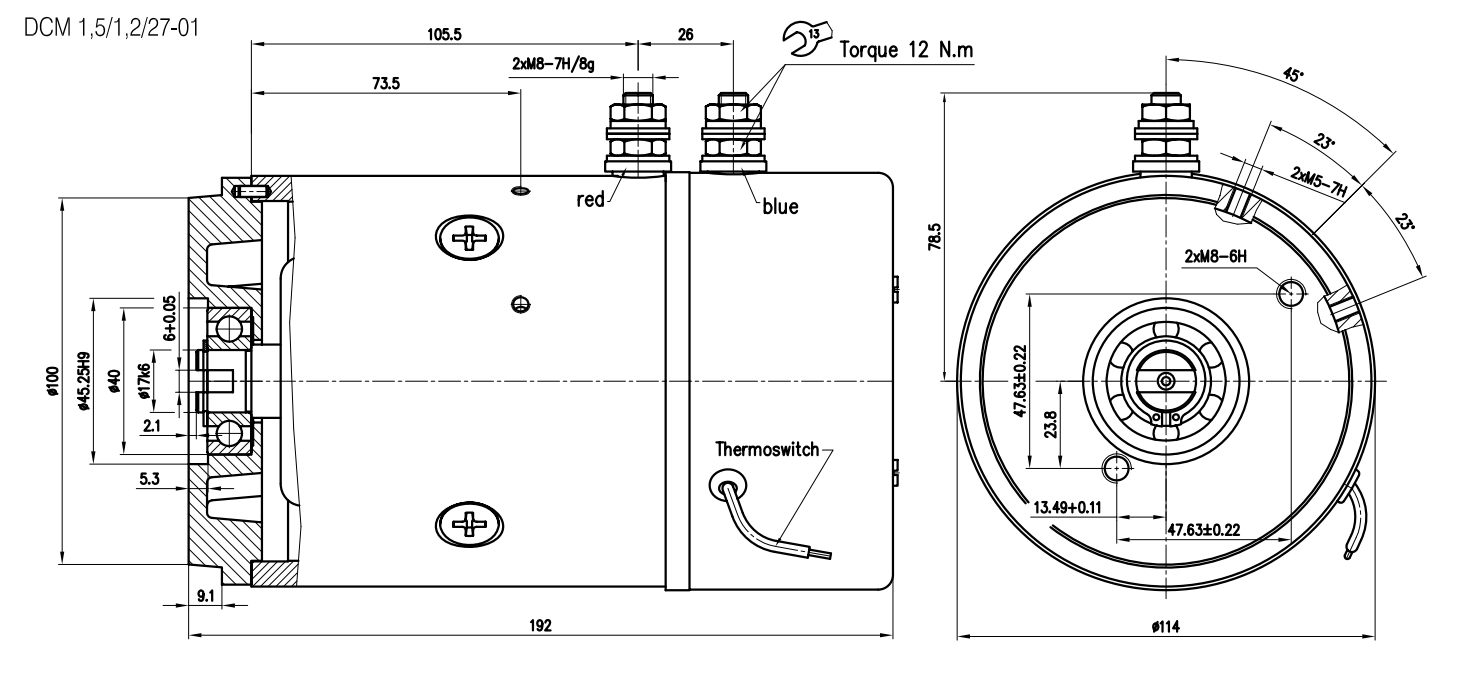

DCM 1,5/1,2/27

DCM 1,5/1,2/27-01

- Rated Power 1,5 kW
- Rated Voltage 12 V
- Rated Current 180 A
- Rated Speed 2700 min.⁻¹
- Operation Mode S2 - 4 min.
- Excitation Compound
- Protection IP 44
- Insulation F
- Weight 6.8 kg / 7.1 kg
- Char. Curve C12 B01
- Rotation C.W.D.E

Connection Diagram

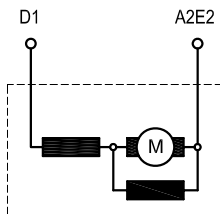

Design versions are adapted to standard assembly dimensions of hydraulic pumps and made according to special requirements of the customers

CAPRONI HOLDING JSC

6100 Kazanlak, BULGARIA
1, Vozheli Str.
Tel: +359 /431/62 229
Fax: +359 /431/ 62 230
E-mail: cip_ltd@mbox.digsys.bg
WEB: http://www.caproni.bg

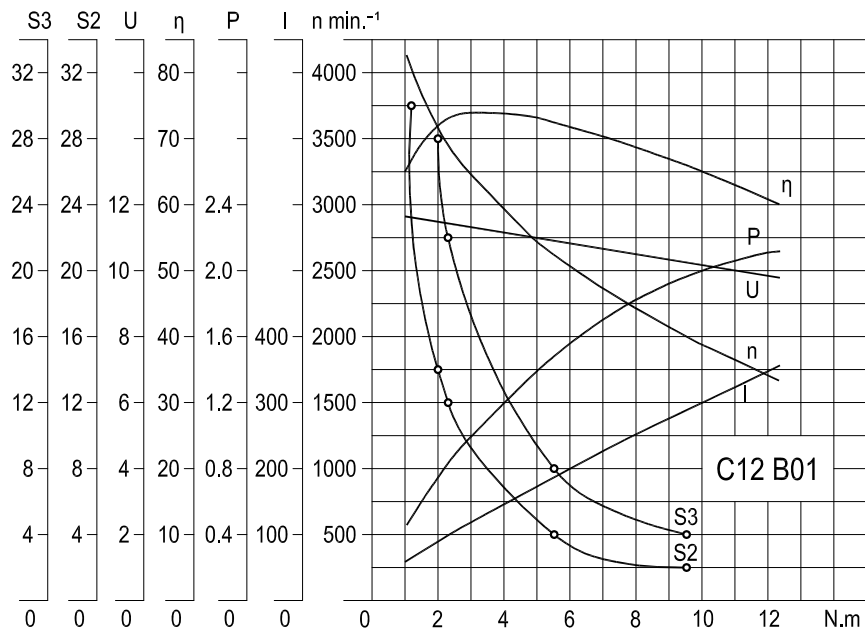

DCM 1,5/2,4/27

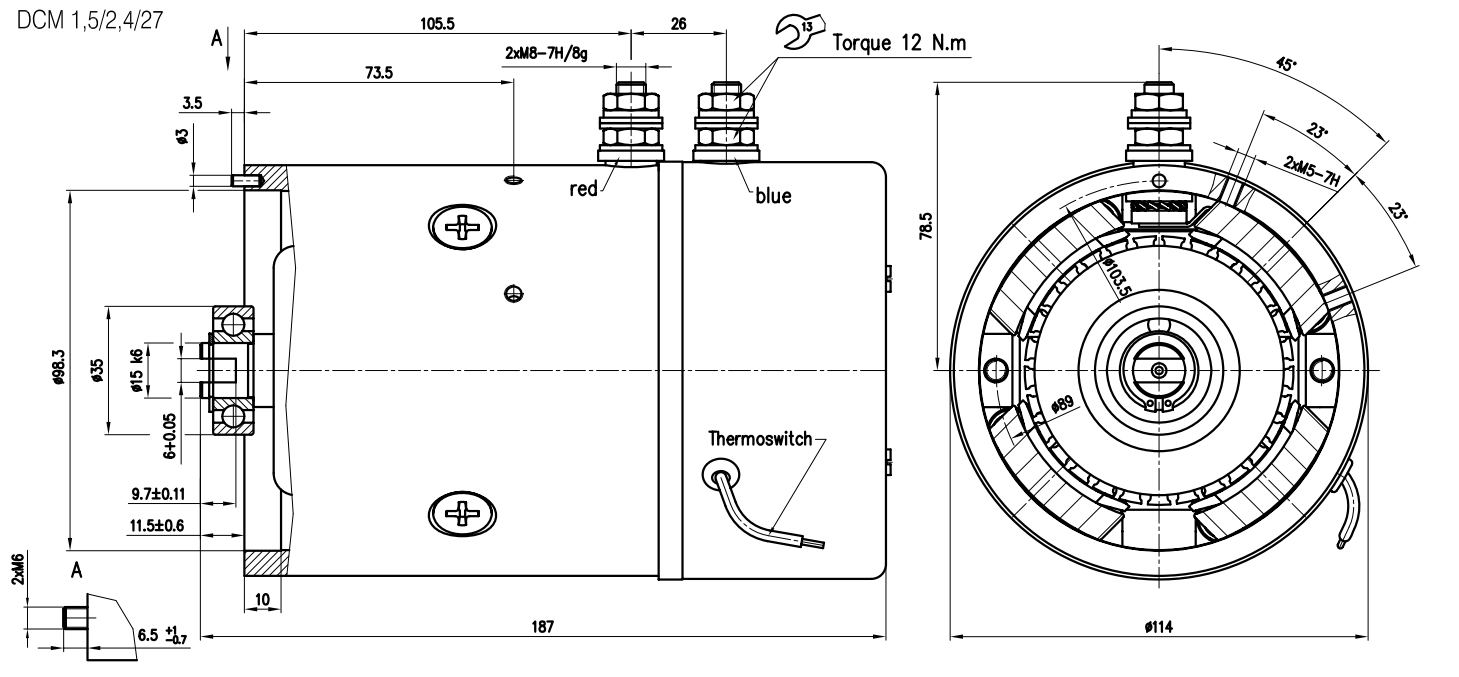

DCM 1,5/2,4/27-01

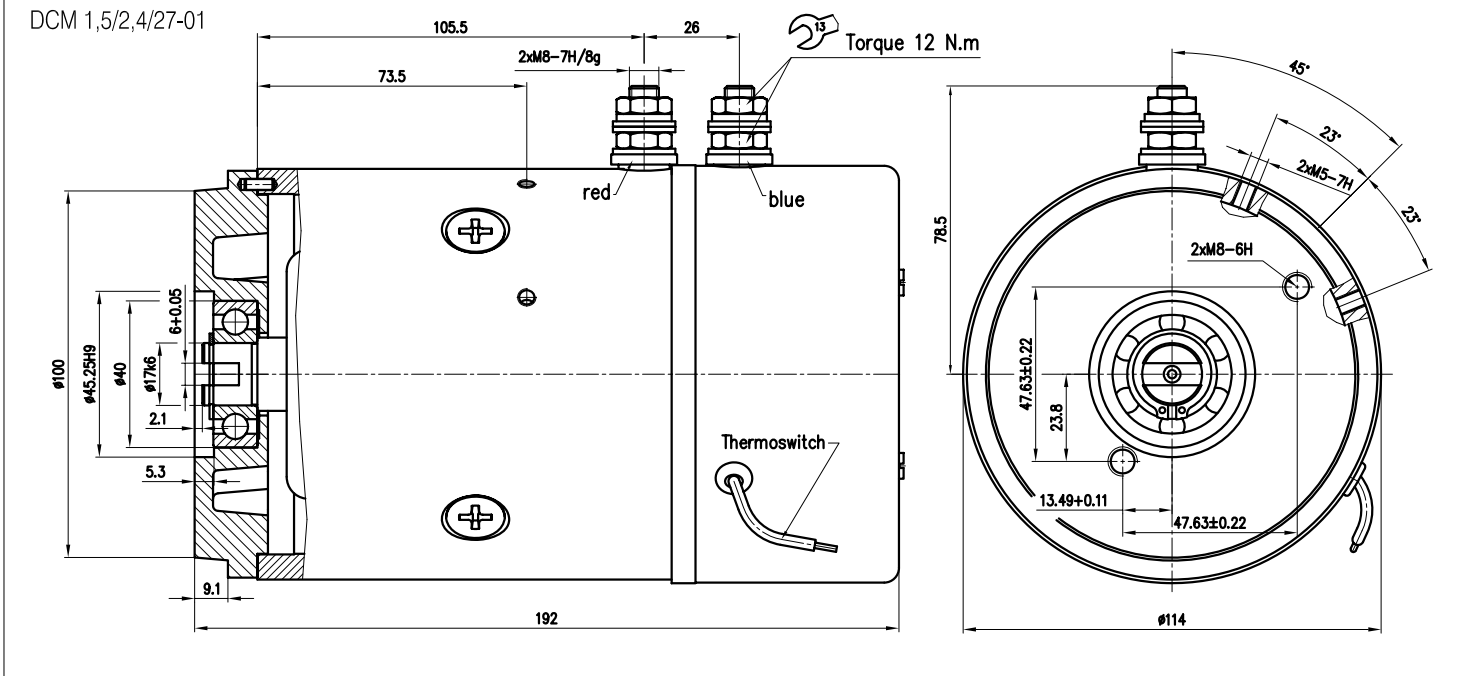

DCM 1,5/2,4/27

DCM 1,5/2,4/27-01

Rated Power 1.5 kW
 Rated Voltage 24 V
 Rated Current 90 A
 Rated Speed 2700 min.⁻¹
 Operation Mode S2 - 5 min.
 Excitation Compound
 Protection IP 44
 Insulation F
 Weight 6.8 kg / 7.1 kg
 Char. Curve C24 B01
 Rotation C.W.D.E

Connection Diagram

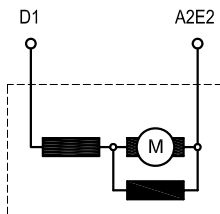

Design versions are adapted to standard assembly dimensions of hydraulic pumps and made according to special requirements of the customers

CAPRONI HOLDING JSC

6100 Kazanlak, BULGARIA
 1, Vozheli Str.
 Tel: +359 /431/62 229
 Fax: +359 /431/ 62 230
 E-mail: cip_ltd@mbox.digsys.bg
 WEB: http://www.caproni.bg

