

DCM 3,0/2,4/35

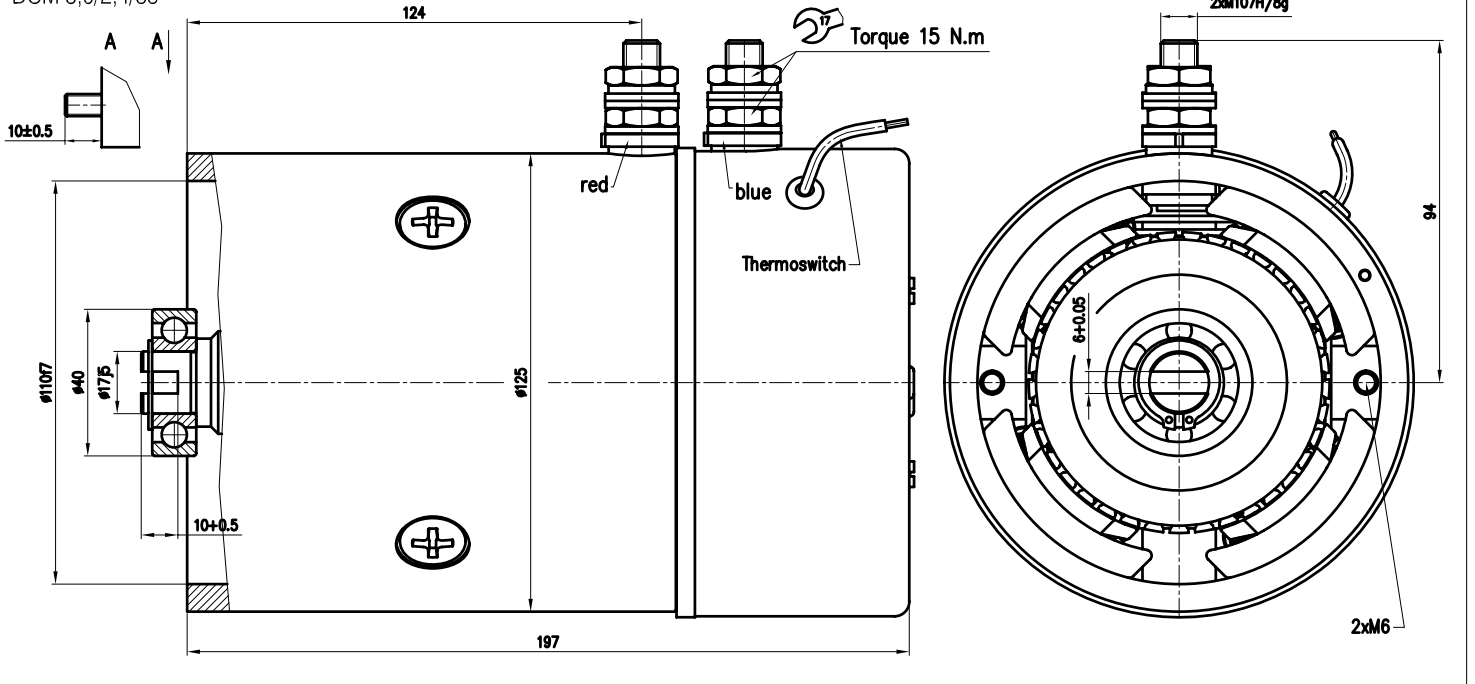

DCM 3,0/2,4/35-01

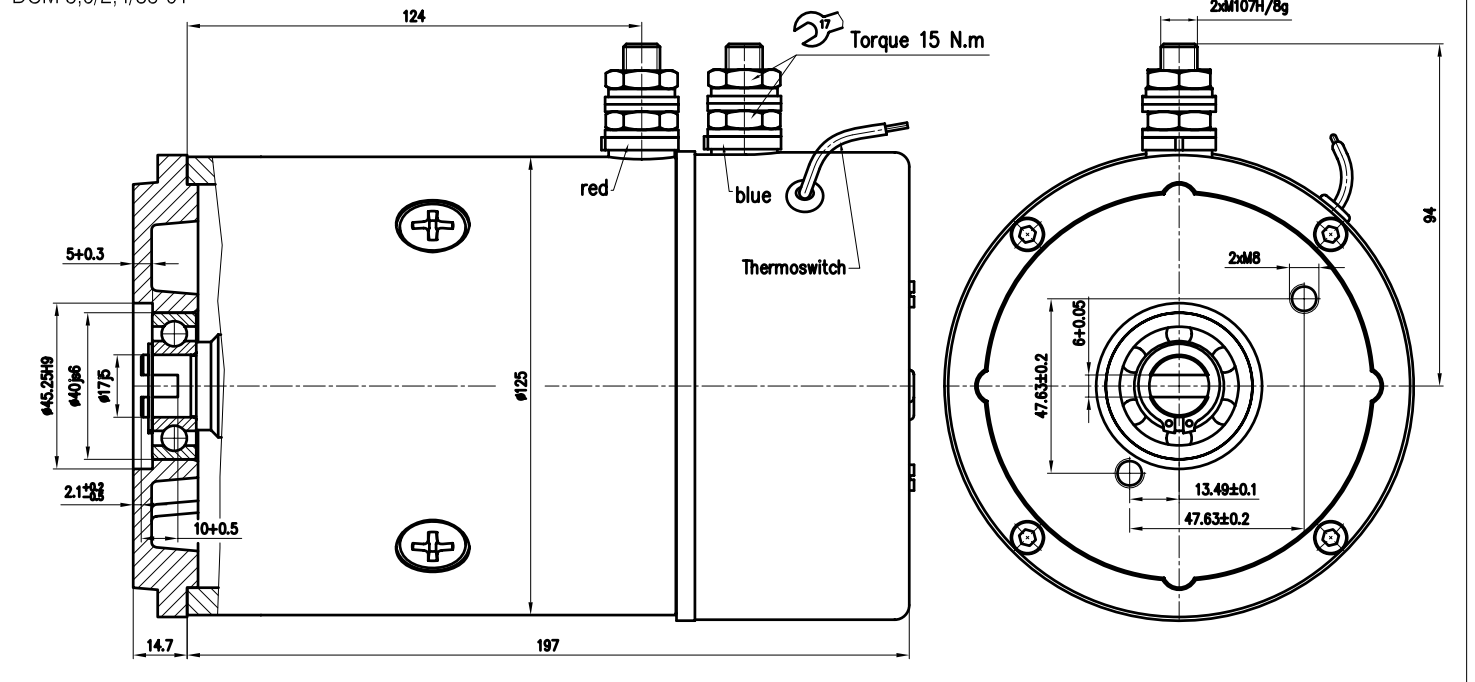

DCM 3,0/2,4/35

DCM 3,0/2,4/35-01

Rated Power	3 kW
Rated Voltage	24 V
Rated Current	168 A
Rated Speed	3500 min. ⁻¹
Operation Mode	S2 - 4.5 min.
Excitation	Compound
Protection	IP 44
Insulation	F
Weight	9.5 kg
Char. Curve	C24 C01
Rotation	C.W.D.E

Connection Diagram

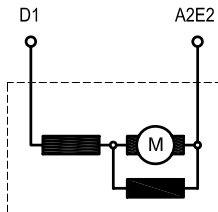

Design versions are adapted to standard assembly dimensions of hydraulic pumps and made according to special requirements of the customers

CAPRONI HOLDING JSC



6100 Kazanlak, BULGARIA
1, Vozheli Str.
Tel: +359 /431/62 229
Fax: +359 /431/ 62 230
E-mail: cip_ltd@mbox.digsys.bg
WEB: <http://www.caproni.bg>

