

**DIMENSIONS AND MOUNTING DATA - HKUS.../3, 4, 8**

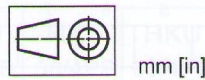
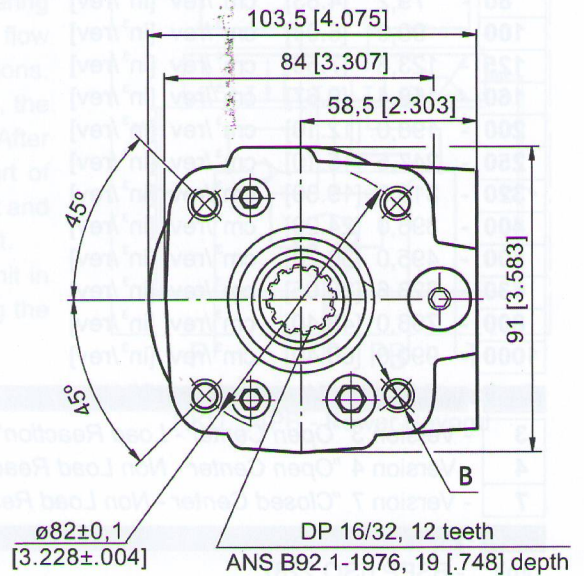
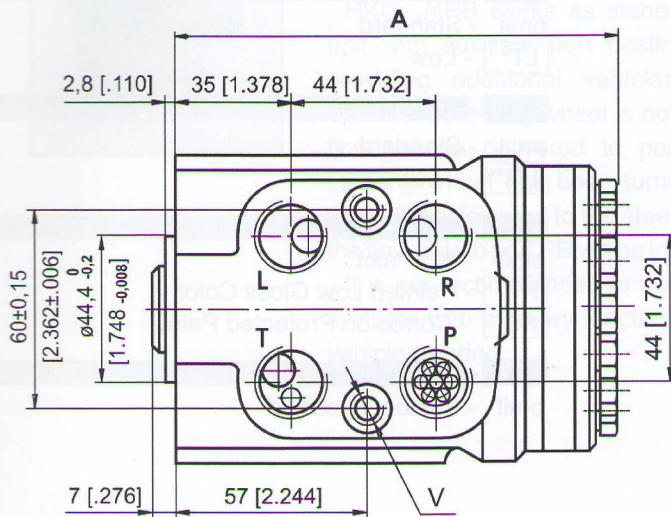

Code	Ports - P*, T, R, L Thread	Column Mounting Thread - B	Valve Mounting Thread - V
-	G1/2 17 [.67] depth	4 x M10 18 [.71] depth	2 x M10x1 16 [.63] depth
M	M22x1,5 17 [.67] depth	4 x M10 18 [.71] depth	2 x M10x1 16 [.63] depth
A	3/4 - 16 UNF O-ring 17 [.67] depth	4 x 3/8 - 16 UNC 15,7 [.62] depth	2 x 3/8 - 24 UNF 14,2 [.56] depth

\*Threaded Ports P min 16 [.63] depth for pipe mounting.